

24 Volt Interface Adapter

INSTALLATION/ APPLICATION MANUAL

208/230V~60Hz,1Ph

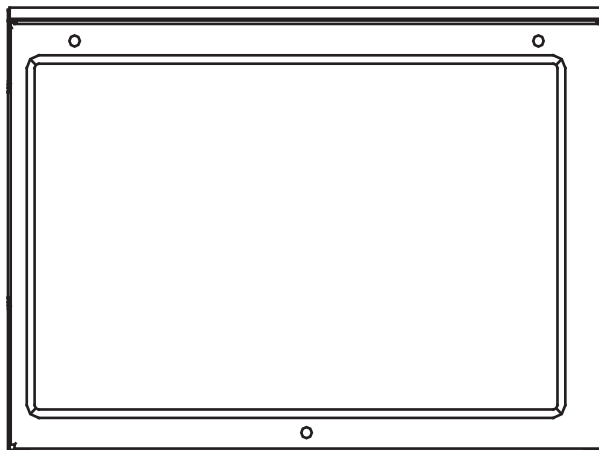

IMPORTANT NOTE:

Read this manual carefully before installing or operating your new 24 Volt Interface Adapter. Make sure to save this manual for future reference.

Table of Contents

Preparation Before Installation.....	1
Installation Method.....	2
System Configuration.....	2
Application.....	3
Control Logic.....	7
DIP Switch Definitions.....	8
Error Codes.....	9

24 Volt Interface Adapter

This adapter is designed for controlling AHU & Acoil & the other air conditioner which can't connect with 24V thermostat.

Features

- Matches the mainstream thermostats on the market.
- Compatible with RS485 and current loop two communication methods.
- Supports DF & L 24V signal output and dry contact DIY control.
- Optional tube temperature and room temperature sensors.

! WARNING

- Wires must be properly sized according to the NEC/NFPA 70, CEC and all prevailing codes, ordinances and standards.
- All conductors must be installed with a strain relief eliminating stress on the wire following installation which may result in wire damage and/or overheating with a potential for fire.
- Installation must be performed in accordance with the requirement of NEC and CEC by authorized personnel only.
- All wiring to be rated for the control box amperage rating.
- All wiring installed to meet general industry standards and practices.
- Do not install adapter near flammable liquids or gases.
- Do not operate the unit with wet hands, as this could lead to electrical shock.

! CAUTION

- When connecting with RS 485 communication to the outdoor unit, shielded wire must be used and grounded at one end only.
- When using shielded wire the cable should be grounded at one end to reduce EMI.
- T1 sensor cable shall not exceed 23' (7 m).

Read this manual carefully before installing or operating your new air conditioning unit. Make sure to save this manual for future reference.

Wall-Mounted 24V INTERFACE KIT Installation

Wear appropriate personal protection equipment (PPE) when installing or servicing.

24V INTERFACE KIT Dimensions

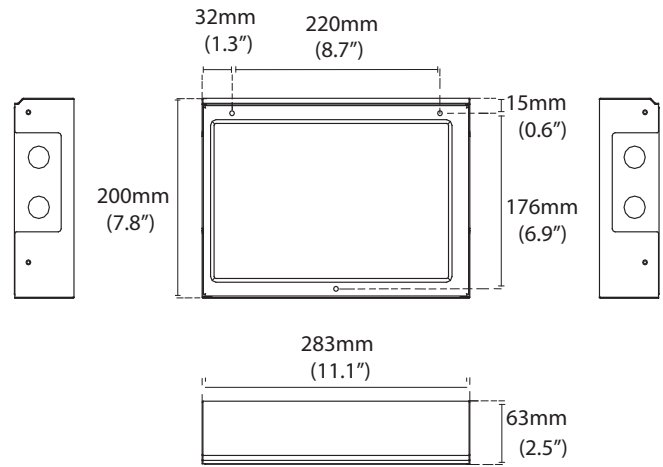
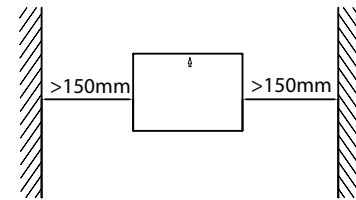

Fig. 1

This interface must be installed indoors in an area free from drips and moisture. This 24V INTERFACE KIT must be installed indoors in a dry area away from moisture and condensation. Maintain at least 5.9" (150mm) spacing to walls and ensure it is elevated from areas that can retain water.



General installation instructions Location and clearances

Preparation Before Installation

1. Ensure you have the following parts

No	Name	Quantity	Remarks
1	Control box	1	
2	Screws	3	M4*20 (For mounting on the wall)
3	Anchors	3	For mounting on the wall
4	Room Temp. Sensor (T1)	1	For connecting the sensor
5	Room Temp. Sensor line (T1) (5m)	1	
6	Coil Temp. Sensor (T2) (1.6m)	1	
7	Ferrite Clamp	1	
8	Zip tie	1	

2. Prepare the following tools

No	Name	Quantity
1	Switch box	1
2	Wiring tube (insulating sleeve and tightening screw)	1

3 Select installation location.

DO NOT install the 24V INTERFACE KIT near flammable liquids or gases such as gasoline or hydrogen sulfide. Doing so creates a fire hazard.

Installation Method

1. Remove the cover of the 24V INTERFACE KIT by removing all 8 exposed screws with a phillips head screwdriver. Next, remove the cover by rotating up (NOTICE: this may be tight due to the foam gasket seal).

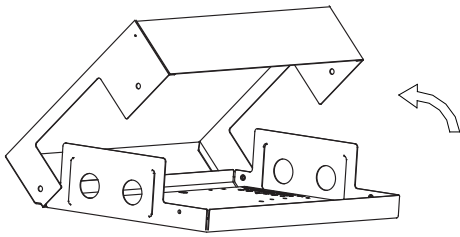

Minimum clearance required around the kit is 7"(180mm).

2. Mount the back plate of the 24V INTERFACE KIT

Mount 24V INTERFACE KIT vertically, and folding in on, fasten the back plate to the wall with 3 screws (M4x20) and anchors.

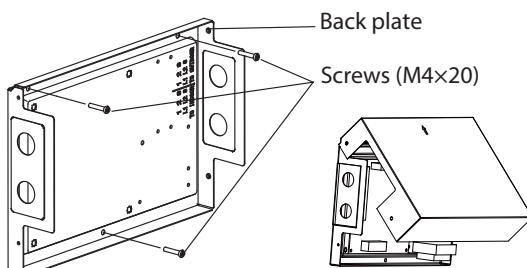

Fig. 3

NOTICE

Place the unit on a flat surface. Be careful not to distort the back plate of the 24V INTERFACE KIT by over tightening the screws. When installed vertically, the direction of the arrow on the cover, must point up.

3. Wiring.

NOTICE

The power to the unit must be disconnected before any wiring. Be sure to show application of ferrite clamp and room temp sensor and cable. Make note to review the different application (scenarios) options for proper wiring. Make sure strain relief and proper conduit are used when connecting to the box.

4. After the wiring is complete, reattach the cover by rotating down from the top, being sure not to pinch any wiring and tightening the 8 attachment screws. Cover the 24V INTERFACE KIT lid, locking screw.

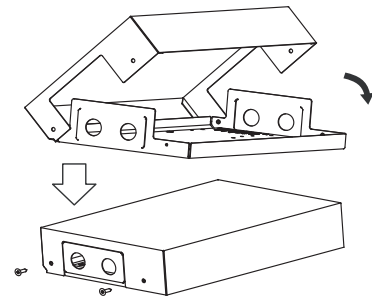

System Configuration

NOTICE

Once configured, only the 24V connected thermostat control should be used to operate the air conditioning system. If other controllers had been connected, please remove. However, the Swing and LED functions on some indoor units will remain functional.

Connection wiring specification

Conncetion wiring	Outdoor (L1)1,(L2)2,(S)3	Indoor (L1)1,(L2)2,(S)3	R/C/Y1/Y2/G/W/W1/B/O/E/AUX/DH/L/DF/WI-out/G1、G2、G3/Work/Alarm
Size	Refer to outdoor connecting wires size	Refer to indoor connecting wires size	24AWG (minimum)

Application

This system is designed for operation with standard 24 vac HVAC thermostats. Wifi standard configuration HVAC thermostats may be used such as NEST, Ecobee, Honeywell, etc.

SYSTEM CONFIGURATION SCENARIOS

NOTICE

For the configuration No.1 & No.2 , The following issues need to be noted.

- T1(Room temperature) sensor should be located in the air inlet side.
- T2(The pipe temperature) sensor can be used to control anti freezing, but it needs to be placed in a suitable position according to the actual situation.
- The TXV or other metering device on the indoor unit must be removed. Because the outdoor unit has been equipped with throttling equipment already.
- If the indoor unit has a 24 volt transformer the 24 volt transformer installed in the interface must be disconnected and preferably removed. Connecting two 24 volt transformers will damage the mainboard.

Configuration No. 1:

Current Loop Communication of Indoor Fan WITH 24V Transformer For current loop (L1/L2/S or 1/2/3) communication of inverter outdoor unit matched with other branded 24V indoor unit.

For the indoor unit with transformer

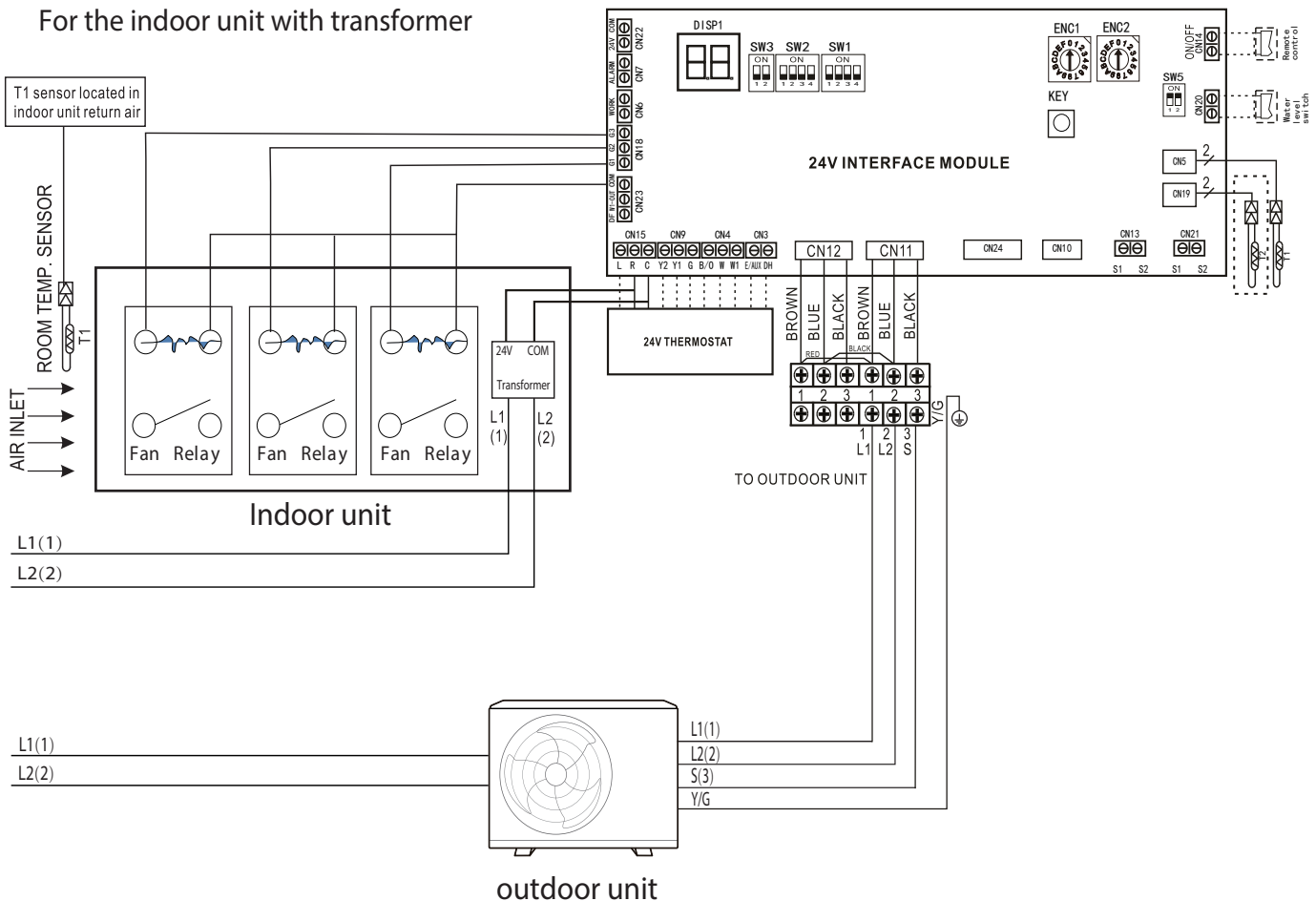

For the indoor unit without transformer

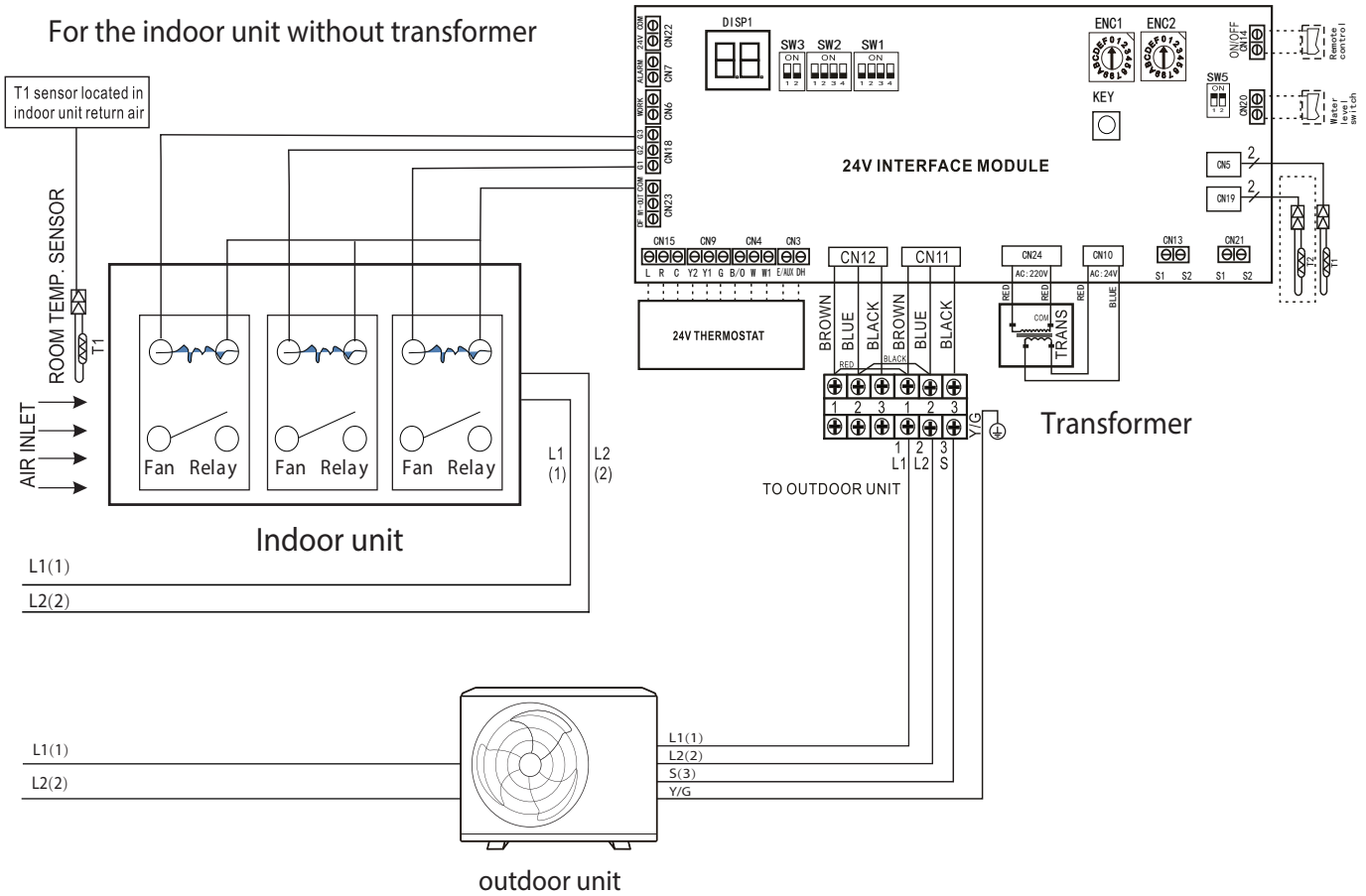

Configuration No. 2:

485 Communication of Indoor Fan WITH 24V Transformer For 485 (P/Q or S1/S2) communication of inverter outdoor unit matched with other branded 24V indoor unit.

For the indoor unit with transformer

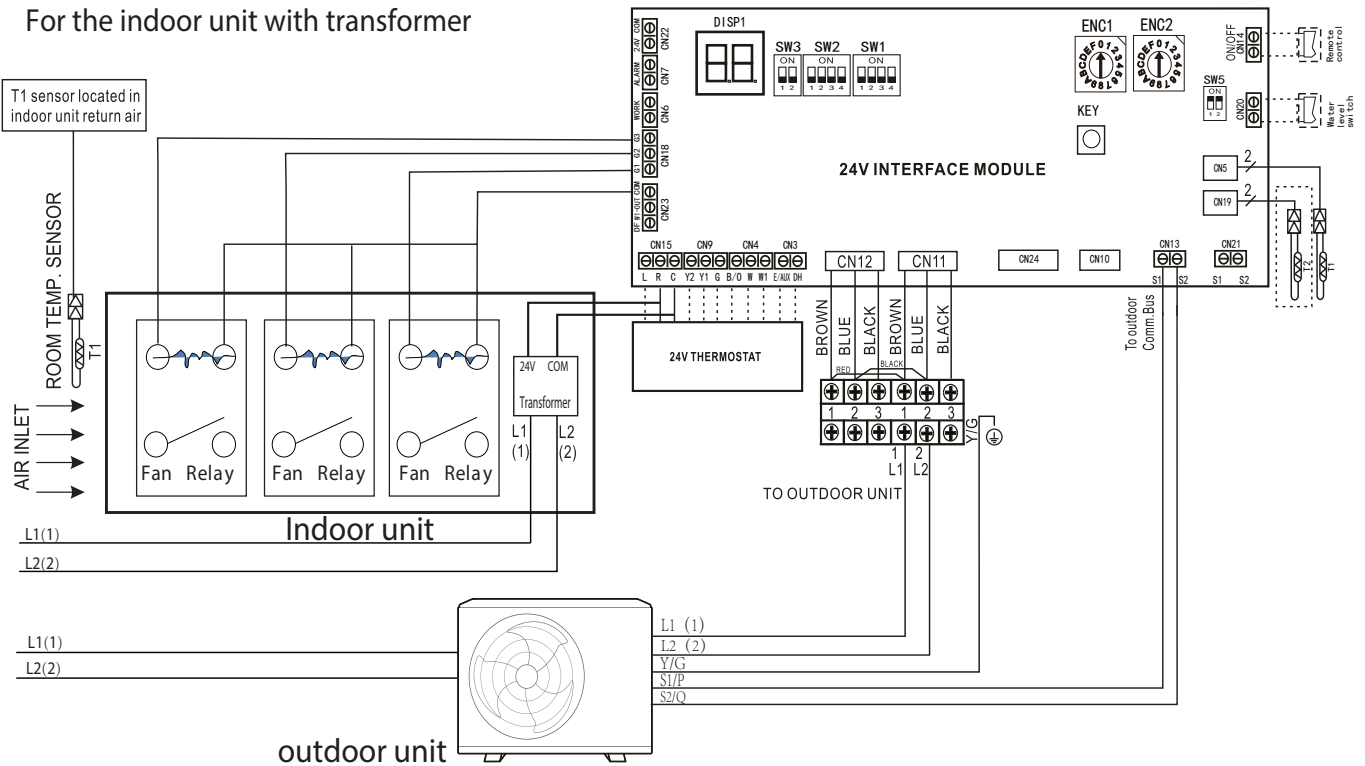

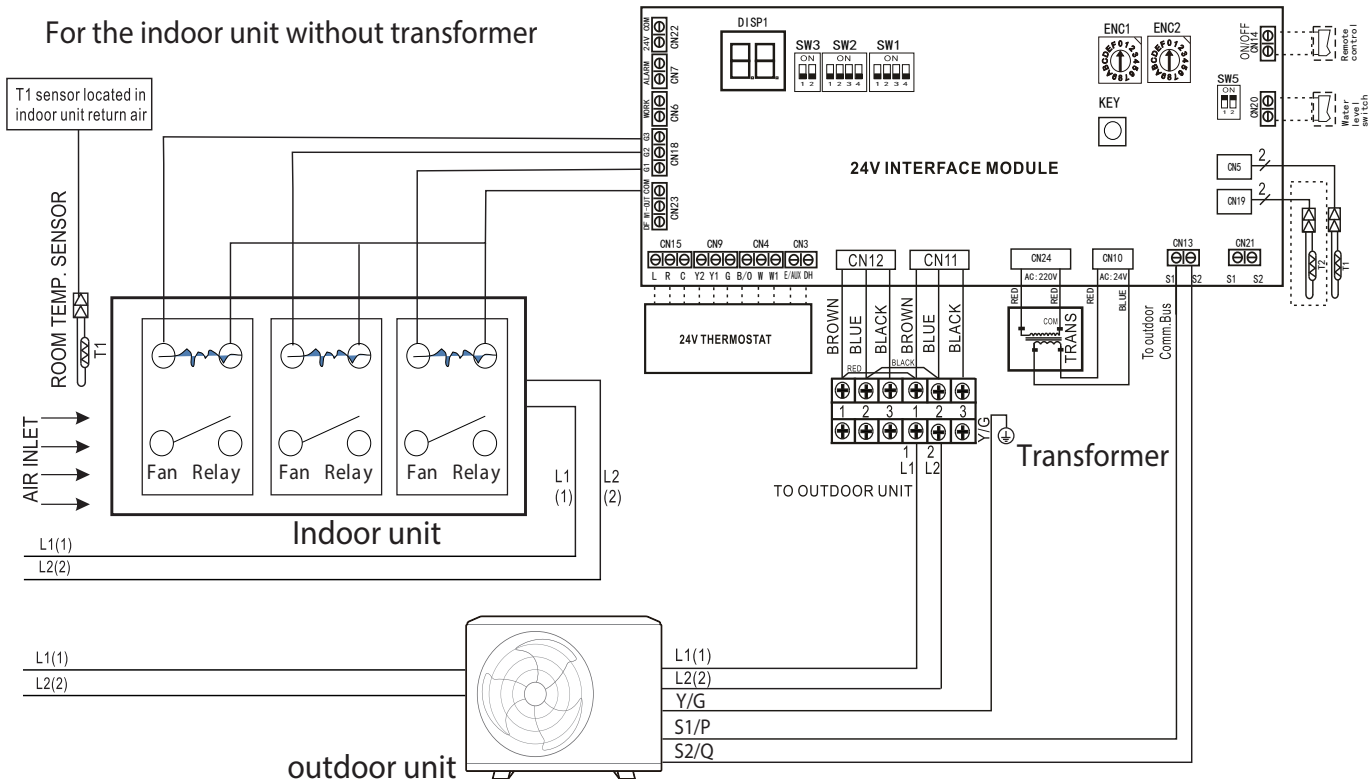

Configuration No. 3:

Current loop (L1 L2 S or 1 2 3) inverter outdoor unit match with current loop inverter indoor unit.

Match the following indoor units with the corresponding compatible SINGLE ZONE and multi zone outdoor units:

- Wall Mounted (Sizes 9K~36K)
- Cassette (Sizes 9K~24K)
- Ducted (Sizes 9K~24K)
- Console (Sizes 9K~12K)
- Floor ceiling (Sizes 18K~24K)
- Multi system (2 zone, 3 zone, 4 zone, 5 zone)

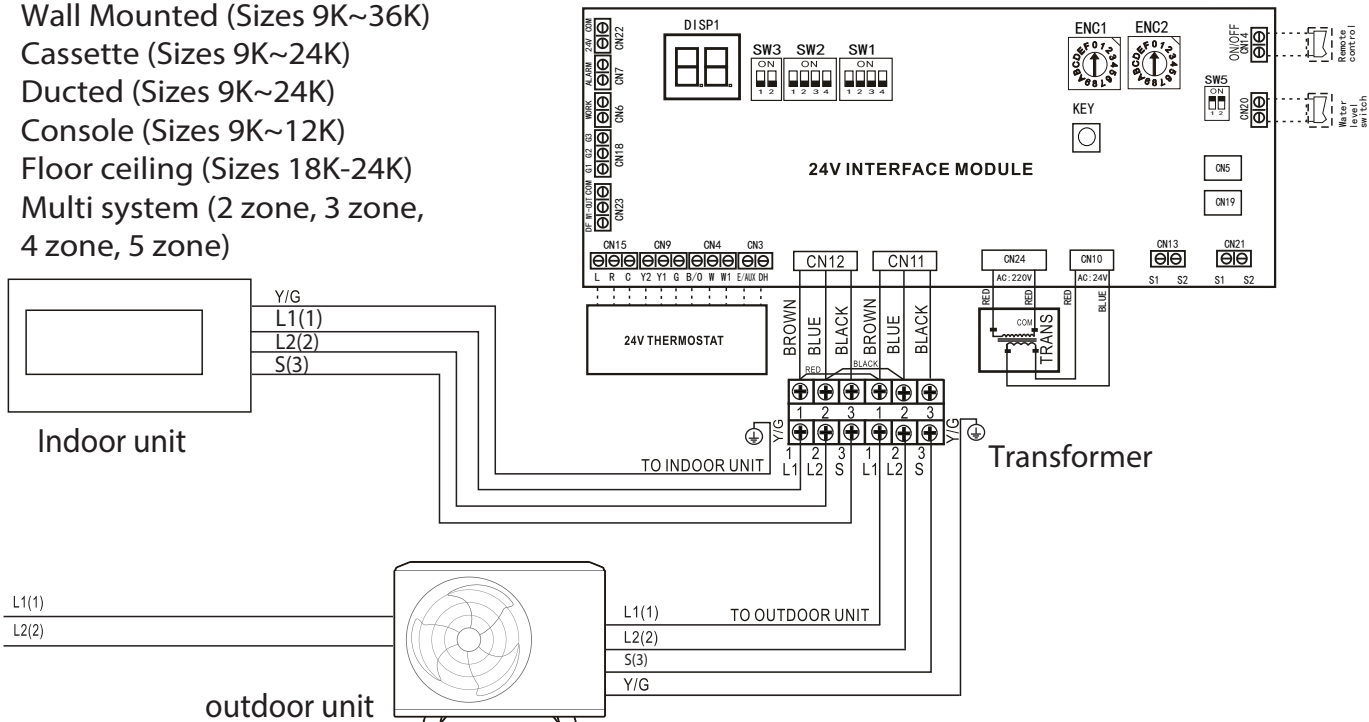

NOTICE

For Wall Mounted unit , the up-down swing louver and the display on/off function is available by the wireless remote controller.
Remove T1 sensor on the adapter when the indoor unit which has T1 sensor.

Configuration No. 4:

485 (P Q) or (S1 S2) inverter outdoor unit match with 485 inverter indoor unit;
 Match the following indoor units with the corresponding compatible SINGLE ZONE outdoor units:
 Cassette (Sizes 36K~48K)
 Ducted (Sizes 36K~60K)
 Floor ceiling (Sizes 36K~60K)

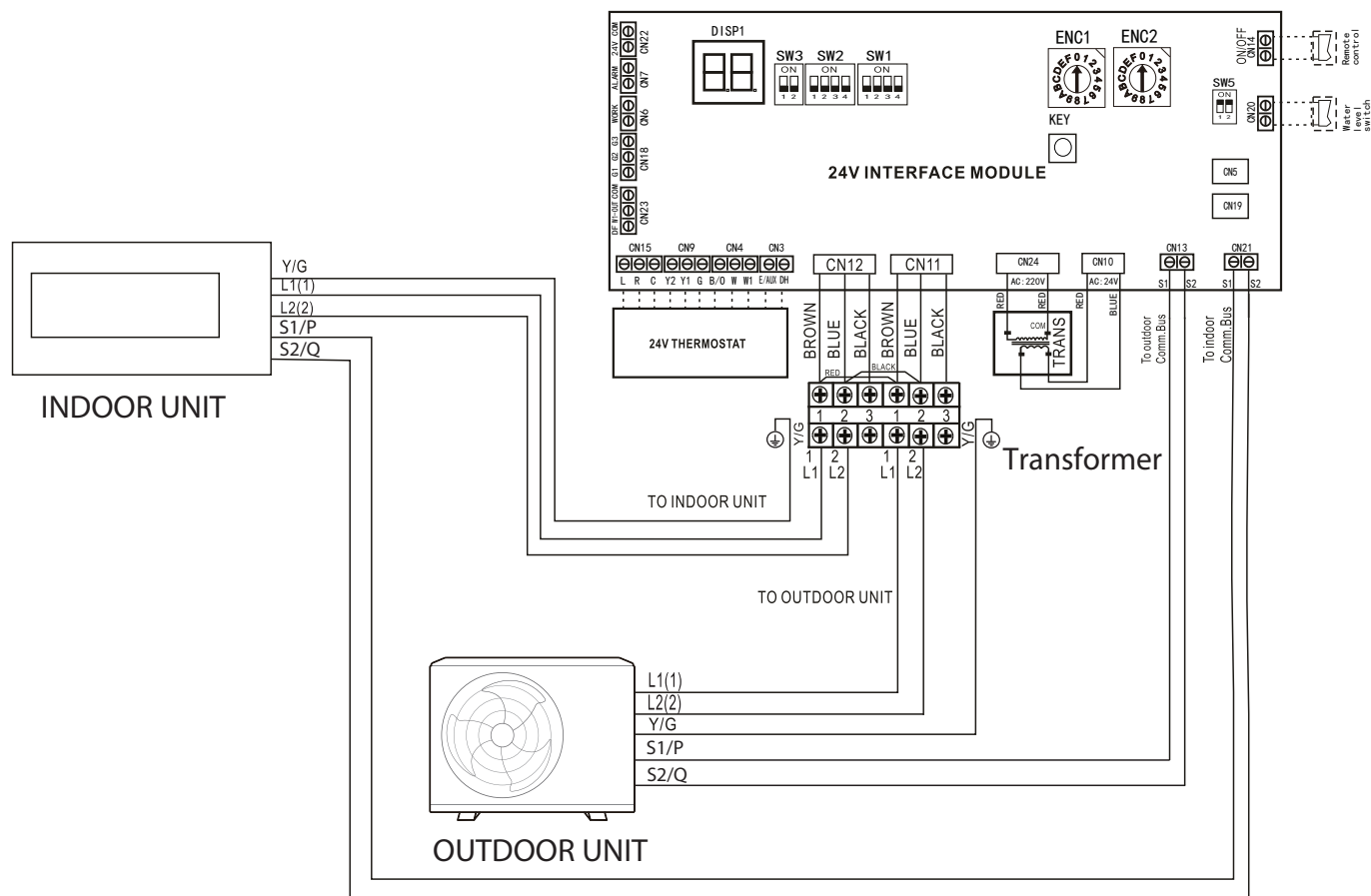

NOTICE

Make sure the power supply is correctly installed.
 Remove T1 sensor on the adapter when the indoor unit which has T1 sensor.
 Please connect thermostat G to 24V interface G as default.



Key Considerations

- The following steps should be taken when using this device with a conventional central air conditioning unit:
 - * Indoor coil metering device must be removed.
 - * 24V transformer in the interface module must be disconnected.
 - * Refrigerant charge amount may need to be adjusted, depending on the pipe size and length, see outdoor recharge instruction.
 - * The maximum air flow should not exceed 400 CFM/Ton.
- Suction and liquid refrigerant lines must be properly insulated to prevent condensation and energy loss.
- You must remove the expansion device from an indoor evaporator coil as the refrigerant is controlled by a metering device in the outdoor unit.
- The following steps should be taken when using this device with a Hi wall (9K-36K Btu/hr) Cassette, Console, Duct, Floor Ceiling (9K - 24K Btu/hr).
- Capacity switch on new board is changed.
- Indoor unit capacity switch setting, ENC-1 must be changed to the proper motor wattage:
Eg. 36K = 8 48K = 9

Control Logic

Input Connector

Connector	Purpose
G	Fan Control
Y1	1st stage compressor
Y2	2nd stage compressor
B/O	Reversing valve
W	Heating control
W1	Electric Heating
E/AUX	Emergency Heating
DH	Dehumidification

Output Connector(24V AC)

Connector	Purpose
L	Malfunction signal
DF	Defrost control
W1-out	24V output(synchronized with W1)
COM	24V(Common)for DF and W1-out
G1、G2、G3	Fan control
Work	Output synchronized with run signal
Alarm	Output synchronized with system fault signal
24V COM	Output synchronized with run signal

G1、G2、G3 output ports to FAN speed Comparison table

Connector	Fan speed			
	High	Middle	Low	OFF
High speed output G3	√	×	×	×
Middle speed output G2	√	√	×	×
Low speed output G1	√	√	√	×

√: 24VAC output

×: NULL

DIP Switch Definitions

DIP SWITCHES CONFIGURATION

The 24V INTERFACE KIT must be configured to operate properly with the system components with which it is installed. To successfully configure the system move the Dip Switches to match the components and functions used.

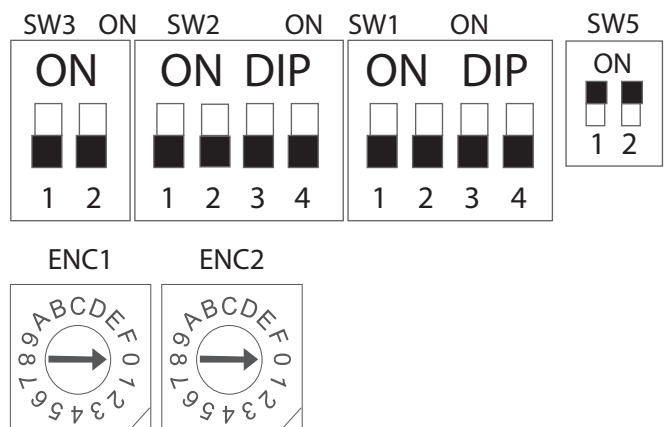

DIP Switch Definitions

DIP switch SW1-2

Used to set the change time of adjusting the virtual target temperature value.

In Cooling/Heating mode, the 24V adapter will control the system keep cooling/heating 0.5H (0.5H is default setting, the SW1-2 is set to off, if you want to change it to 1H, SW1-2 switch should be set ON), and keep the set virtual target temperature value will not be adjusted until the thermostat sends a shutdown signal.

Once the system running time over the set value, the system will adjust virtual set temperature for faster cooling or heating. The purpose is to make the room temperature reach the set value of the thermostat, and stop the system.

SW1-2	Result	Note
ON	1H	
OFF	0.5H	default

DIP switch SW1-3

Used to Control the electric heating output W1 OUT to start according to the continuous running time of the compressor.

SW1-3	Result	Note
ON	1H	
OFF	off	default

DIP switch SW2-1

Use to set the Electric heater start-stop temperature difference According to T4 limits: T4_W1_TEMP.

SW2-1	Result	Note
ON	1°C	
OFF	2°C	default

DIP switch ENC2

ENC2 : Use to set the temperature protection according to environment temperature for control the electric auxiliary heater.

0: OFF

1 - F : ON, SET the protect temperature as follows in this table(-20°C -8°C), $T4 < ENC2'S$ value, start the electric auxiliary heater.

$T4 > T4_W1_TEMP + ENC2'S$ value, the electric auxiliary heater will be turn off.

ENC2	ENC2(°C)
0	invalid
1	-20
2	-18
3	-16
4	-14
5	-12
6	-10
7	-8
8	-6
9	-4
A	-2
B	0
C	2
D	4
E	6
F	8

DIP switch ENC1

ENC1	capacity	ENC1	capacity
0	6K	8	36K
1	9K	9	42K
2	12K	A	48K
3	null	B	60K
4	18K	C	null
5	24K	D	null
6	null	E	null
7	30K	F	null

DIP switch SW2-3

Used to set whether the T2 function is valid.

SW2-3	Result	Note
ON	valid	
OFF	invalid	

If you set the T2 function is valid, please refer to the service manual, make sure the T2 is professionally installed.

DIP switch SW5-1

Used to set the water level switch function.

SW5-1	Result	Note
ON	invalid	default
OFF	valid	

DIP switch SW5-2

Used to set the remote switch function.

SW5-2	Result	Note
ON	invalid	default
OFF	valid	

The function of the KEY

When the condenser of the outdoor unit got frosted. You can start the forced defrost mode by pressing this key button. The operation mode is: long press the button for more than 3 seconds.

Error Codes

Display	Malfunction & protection indication
E0	Indoor EEPROM error
E2	Cross-zero detection error
E3	Indoor fan speed malfunction
E4	Indoor room temperature sensor error
E5	Evaporator coil temperature sensor error
EC	Refrigerant leak detection system malfunction
EE	Water level warning error
F0	Current overload protection
F1	Outdoor ambient temperature sensor (T4) malfunction
F2	Condenser coil temperature sensor (T3) malfunction
F3	Compressor discharge temperature sensor (T5) malfunction
F4	Outdoor unit EEPROM parameter error
F5	Outdoor fan speed has been out of control
F6	T2b sensor error
P0	Inverter module (IPM) malfunction
P1	Over-voltage or under-voltage protection
P2	Compressor top high temperature protection (OLP)
P3	Low ambient temperature cut off in heating
P4	Compressor drive malfunction
--	Mode conflict
P6	Compressor low-pressure protection
00	Module boot mode and indoor running mode for power off
IN	Module and indoor unit communication malfunction
OU	Module and outdoor unit communication malfunction

The design and specifications are subject to change without prior notice for product improvement. Consult with the sales agency or manufacturer for details.

QSKZHI-003AEN
1611160000168
20220602

此面无需印刷

技术要求:

1. 双胶纸(说明书)80g非E项目大度
2. 尺寸: A4
3. 颜色: 黑白
4. 注意: 排版时注意页码数字都是靠外面的, 以便翻阅
5. 装订。