

R454b Refrigerant

SUBMITTAL DATA SHEET



Model number: ECCC-36U/ECUO-36E

Air Handler Heat Pump System

Location:	Approval:
Engineer:	Date:
Submitted to:	Construction:
Submitted by:	Unit #:
Reference:	Drawing #:



INDOOR SPECIFICATION

Dimension (W×D×H)	inch	21 x 21 x 24
	mm	534 × 533 × 611
Package (W×D×H)	inch	20-1/2 x 26-1/8 x 26-3/8
	mm	610 × 665 × 685
Net/Gross Weight	lbs	64 / 74
	kg	29.2 / 33.6

OUTDOOR SPECIFICATION

Compressor Type	ROTARY	
Compressor Model	KTF310D43UMT	
Refrigerant	R454B	
Refrigerant Oil Charge(mL)	1,000	
Refrigerant Oil	VG74	
Outdoor Air Flow (Max) (CFM)	2,413	
Outdoor Noise Level (dBA)	63	
Dimension (W×D×H)	inch	37-1/4 x 16-1/8 x 31-7/8
	mm	946 × 410 × 810
Package (W×D×H)	inch	42-7/8 x 19-5/8 x 34-7/8
	mm	1090 × 500 × 885
Net/Gross Weight	lbs	153 /164
	kg	69.5 / 74.2

EFFICIENCY

Cooling		Heating	
SEER2	14.7	HSPF2-4	9.0
EER2	9.6	COP	3.40

PERFORMANCE OF COOLING

Cooling (Btu/hr)

Rated Capacity	36,000
Min/Max Capacity	12,000~38,600
Moisture Removal(L/h)	4
Standard Operating Range(°F/°C)	-13~122 (-25~50)
Rated Cooling Conditions:	Indoor: 80°F DB/67°F WB Outdoor: 95°F DB/75°F WB

PERFORMANCE OF HEATING

Heating (Btu/hr)

1. @ 47°F Rated	36,000
2. @ 47°F Min/Max Capacity	14,000~41,000
3. @ 17°F Rated	25,600
4. @ 5°F Rated: Capacity / COP	27,200/2.0
5. @ 5°F Max: Capacity	27,200
Standard Operating Range(°F/°C)	-13~75 (-25~24)
1. Rated Heating Conditions:	Indoor: 70°F DB/60°F WB Outdoor: 47°F DB/43°F WB
2. Rated Heating Conditions:	Indoor: 70°F DB/60°F WB Outdoor: 17°F DB/15°F WB
3. Heating Conditions, Compressor Operating at Max. Frequency	Indoor: 70°F DB/60°F WB Outdoor: 5°F DB/5°F WB

ELECTRICAL

Indoor Power Supply	24V,60Hz,1Ph
Indoor MCA 115V/(208/230V)	/
Indoor MOP	/
Outdoor Power Supply	208/230,60Hz,1Ph
Outdoor MCA	24.0
Outdoor MOP	30.0
Communication Wiring	AWG 20/2
Compressor RLA	17.5
Outdoor Fan Motor RLA	1.5
Outdoor Fan Motor W	120
Indoor Fan Motor RLA	/
Indoor Fan Motor W	/
System Power Input @ Cooling (W)	3,750 (1,070~4,700)
System Power Input @ Heating (W)	3,103 (1,200~3,750)
MCA: Min. circuit amps (A)	MOCP: Max. over current protection (A)
RLA: Rated load amps (A)	W: Fan motor rated output (W)

PIPING

Throttle type(Indoor)	TXV
Throttle type(Outdoor)	EXV
Liquid Size	3/8" (9.52mm)
Gas Size	3/4" (19mm)
Max. Piping Length(ft/m)	246 (75)
Max. Height Difference(ft/m)	98.4 (30)
Max. Pre-charged Length(ft/m)	25 (7.5)
Refrigerant Pre-charged Amount (oz/ft³)	116 (3.3)
Additional Charge of Refrigerant(oz/ft³)(g/ft³)	0.7 (65)
Connection Method	Flared

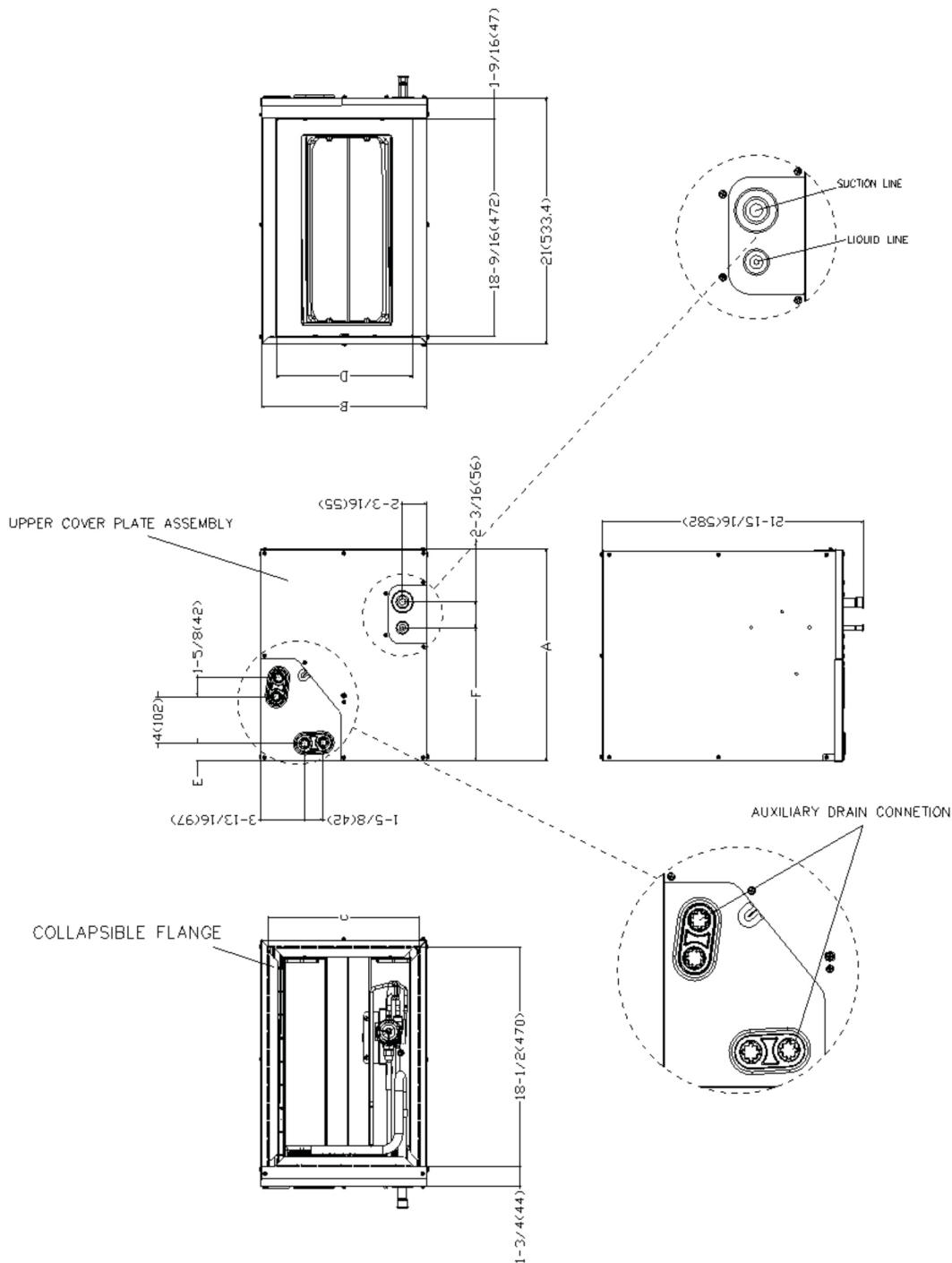

Dimensions		Model(Btu/h)		24-A		36-A		36-B	
		inch	mm	inch	mm	inch	mm		
A	Model Height	18	457	23-5/16	592	23-1/2	599		
B	Model Width	14-1/2	368	14-1/2	368	17-1/2	445		
C	Supply Air Opening Width	13-1/4	336	13-1/4	336	16-3/16	411		
D	Return Air Opening Width	11-15/16	303	11-15/16	303	14-15/16	380		
E	Condensate Drains Height	1-7/16	38	1-7/16	38	1-7/16	38		
F	Liquid Line Height	11-3/8	290	17-15/16	455	16-3/8	417		
Dimensions		Model(Btu/h)		24-B		36-C			
		inch	mm	inch	mm				
A	Model Height	18	457	24	611				
B	Model Width	17-1/2	445	21	534				
C	Supply Air Opening Width	16-3/16	411	19-3/4	502				
D	Return Air Opening Width	14-15/16	380	18-7/16	468				
E	Condensate Drains Height	1-7/16	38	2-3/16	55				
F	Liquid Line Height	11-3/8	290	17-1/2	445				

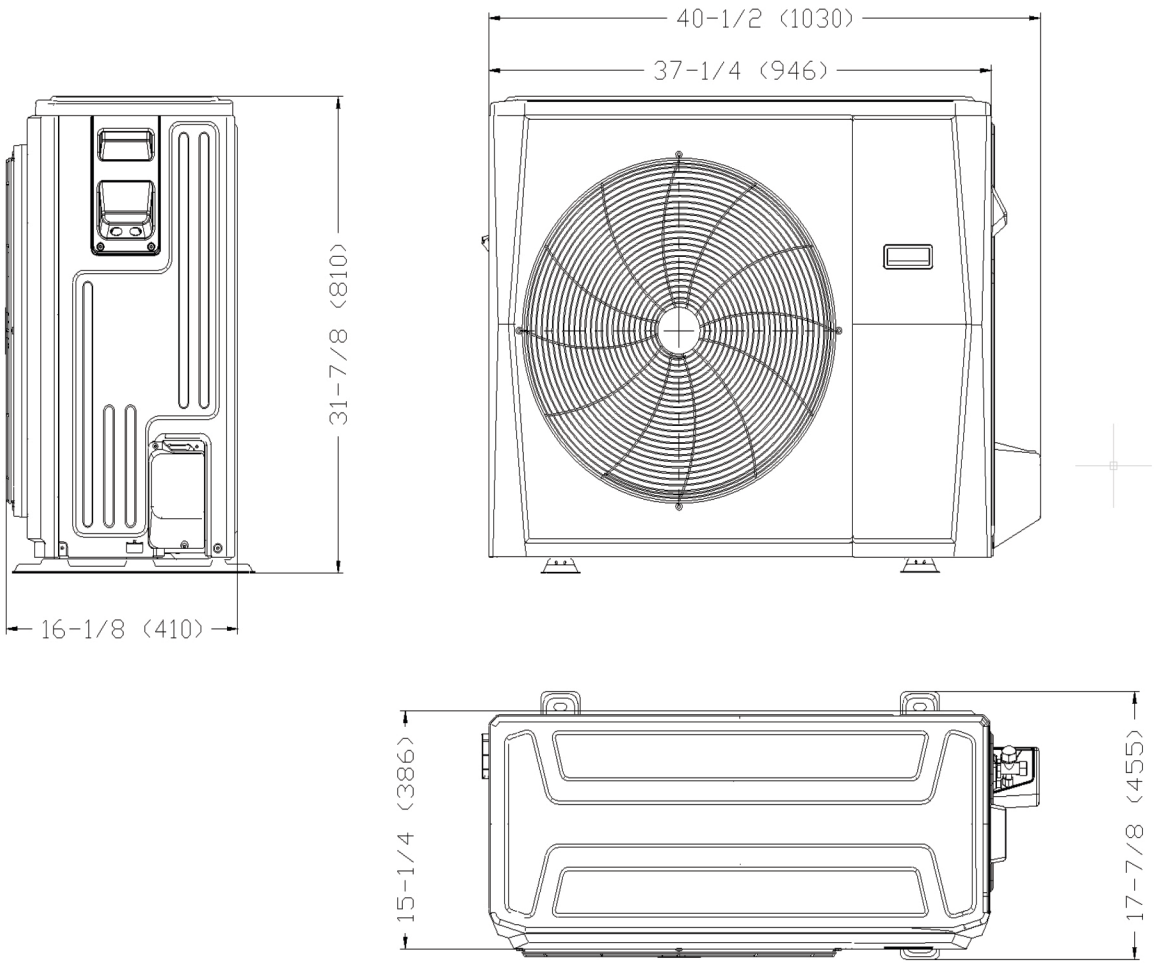

Installation Instructor Outdoor Unit

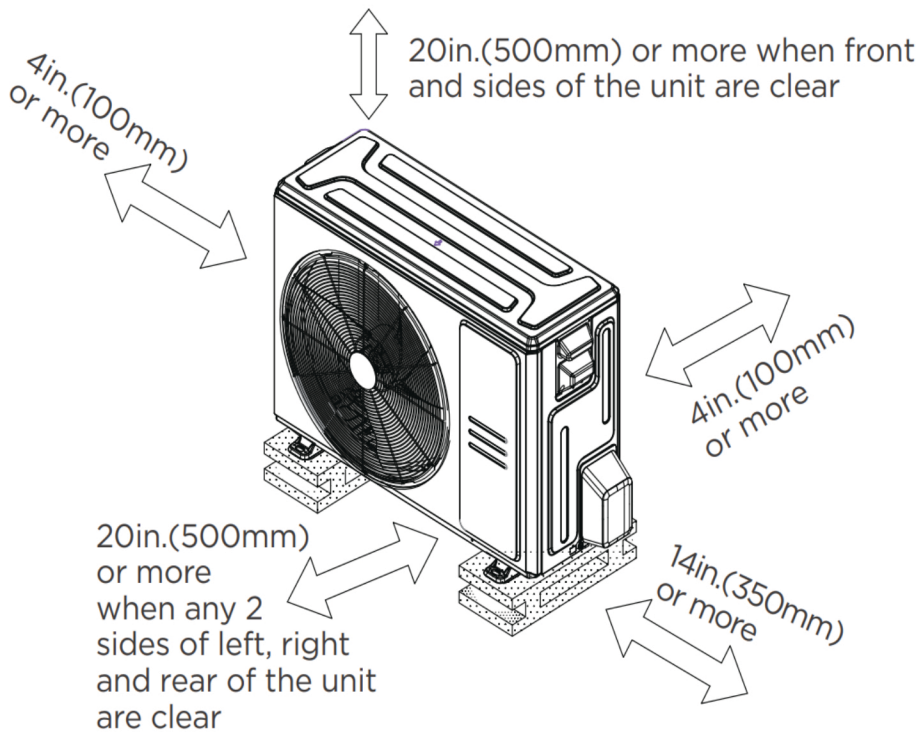

Features

- Multi-position installation: horizontal(left or right), vertical(up or down)
- Aluminum Coil
- R454B refrigerant sensor
- Easy Maintenance
- Multiple control options available:
 - Two way communication wired controller with built-in WiFi:120N(X6W)
 - Third-Party 24V Thermostat