

# R454b Refrigerant

# SUBMITTAL DATA SHEET



Model Number: ECCA-24U/ECUO-24E

## Air Handler Heat Pump System

Location:	Approval:
Engineer:	Date:
Submitted to:	Construction:
Submitted by:	Unit #:
Reference:	Drawing #:



### INDOOR SPECIFICATION

Dimension (W×D×H)	inch	14-1/2 x 21 x 18
	mm	368 × 533 × 457
Package (W×D×H)	inch	17-1/2 x 25-3/8 x 20-5/8
	mm	445 × 645 × 525
Net/Gross Weight	lbs	42 / 50
	kg	19 / 22.5

### OUTDOOR SPECIFICATION

Compressor Type	ROTARY	
Compressor Model	KTM240D46UKT2	
Refrigerant	R454B	
Refrigerant Oil Charge(mL)	620	
Refrigerant Oil	VG74	
Outdoor Air Flow (Max) (CFM)	1,766	
Outdoor Noise Level (dBA)	60	
Dimension (W×D×H)	inch	35 x 13-1/2 x 26-1/2
	mm	890 × 342 × 673
Package (W×D×H)	inch	39-1/8 x 15-5/8 x 29-1/8
	mm	995 × 398 × 740
Net/Gross Weight	lbs	102 / 109
	kg	46.4 / 49.5

### EFFICIENCY

Cooling		Heating	
SEER2	16	HSPF2-4	9.0
EER2	10	COP	3.2

### PERFORMANCE of Cooling

Cooling (Btu/hr)	
Rated Capacity	24,000
Min/Max Capacity	7,900~27,600
Moisture Removal(L/h)	2.89
Standard Operating Range(℉/℃)	-13~122 ( -25~50)
Rated Cooling Conditions:	Indoor: 80℉ DB/67℉ WB Outdoor: 95℉ DB/75℉ WB

### PERFORMANCE of Heating

Heating (Btu/hr)	
1. @ 47℉ Rated	25,000
2. @ 47℉ Min/Max Capacity	6,500~27,000
3. @ 17℉ Rated	19,700
4. @ 5℉ Rated: Capacity / COP	19000/1.8
5. @ 5℉ Max: Capacity	19,000
Standard Operating Range(℉/℃)	-13~75 ( -25~24)
1. Rated Heating Conditions:	Indoor: 70℉ DB/60℉ WB Outdoor: 47℉ DB/43℉ WB
2. Rated Heating Conditions:	Indoor: 70℉ DB/60℉ WB Outdoor: 17℉ DB/15℉ WB
3. Heating Conditions, Compressor Operating at Max. Frequency	Indoor: 70℉ DB/60℉ WB Outdoor: 5℉ DB/5℉ WB

### ELECTRICAL

Indoor Power Supply	24V,60Hz,1Ph
Indoor MCA 115V/(208/230V)	/
Indoor MOP	/
Outdoor Power Supply	208/230,60Hz,1Ph
Outdoor MCA	19.0
Outdoor MOP	20.0
Communication Wiring	AWG 20/2
Compressor RLA	14
Outdoor Fan Motor RLA	1
Outdoor Fan Motor W	/
Indoor Fan Motor RLA	/
Indoor Fan Motor W	/
System Power Input @ Cooling (W)	2,400 ( 680 ~ 2,890)
System Power Input @ Heating (W)	2,290 ( 550 ~2,900)
MCA: Min. circuit amps (A)	MOCP: Max. over current protection (A)
RLA: Rated load amps (A)	W: Fan motor rated output (W)

### PIPING

Throttle type(Indoor)	TXV
Throttle type(Outdoor)	EXV
Liquid Size	3/8" (9.52mm)
Gas Size	3/4" (19mm)
Max. Piping Length(ft/m)	164 ( 50)
Max. Height Difference(ft/m)	82 ( 25)
Max. Pre-charged Length(ft/m)	25 (7.5)
Refrigerant Pre-charged Amount(oz/kg)	74 ( 2.1)
Additional Charge of Refrigerant(oz/ft)/(g/m)	0.7 ( 65)
Connection Method	Flared

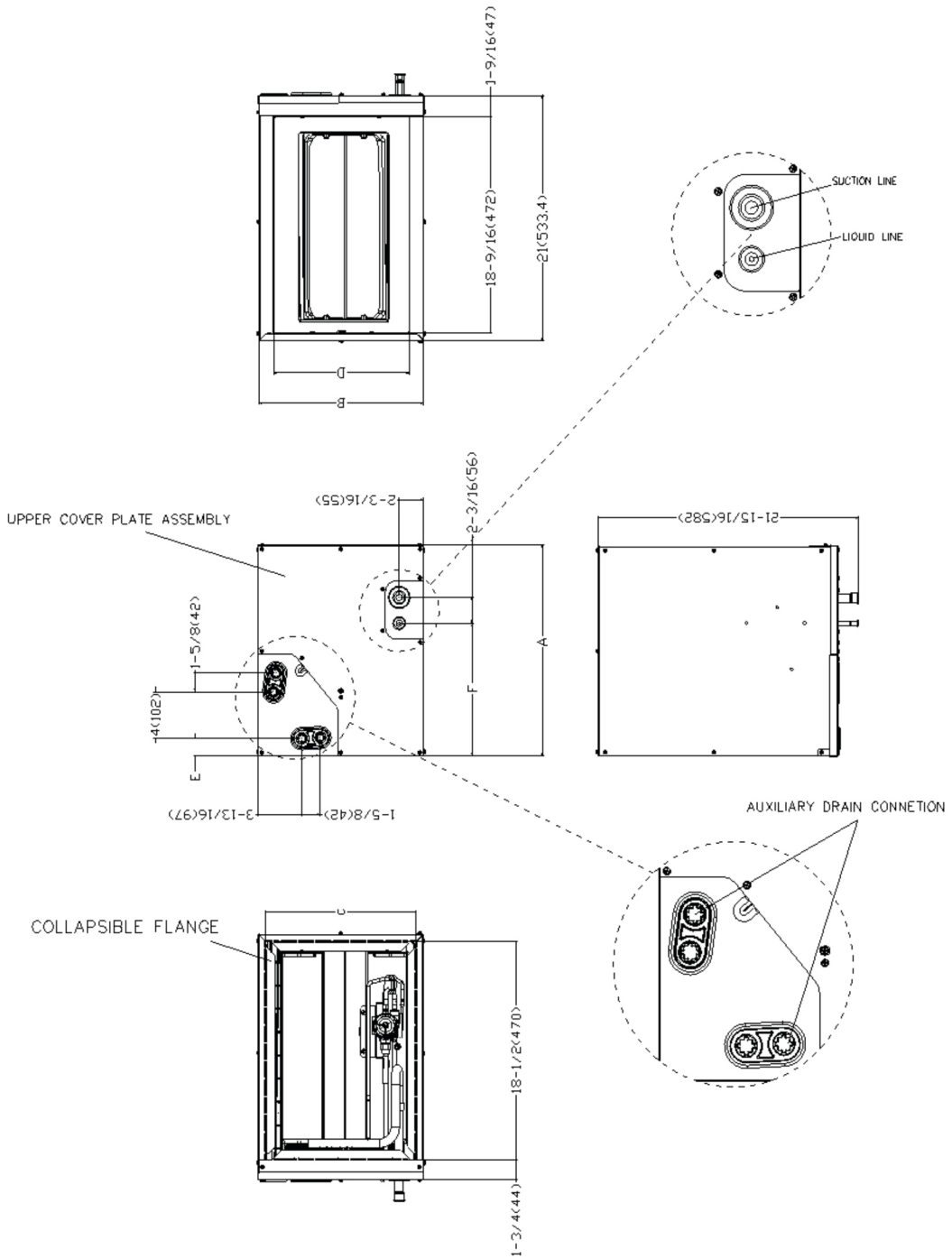

Model(Btu/h)		24-A		36-A		36-B	
Dimensions		inch	mm	inch	mm	inch	mm
A	Model Height	18	457	23-5/16	592	23-1/2	599
B	Model Width	14-1/2	368	14-1/2	368	17-1/2	445
C	Supply Air Opening Width	13-1/4	336	13-1/4	336	16-3/16	411
D	Return Air Opening Width	11-15/16	303	11-15/16	303	14-15/16	380
E	Condensate Drains Height	1-7/16	38	1-7/16	38	1-7/16	38
F	Liquid Line Height	11-3/8	290	17-15/16	455	16-3/8	417
Model(Btu/h)		24-B		36-C			
Dimensions		inch	mm	inch	mm		
A	Model Height	18	457	24	611		
B	Model Width	17-1/2	445	21	534		
C	Supply Air Opening Width	16-3/16	411	19-3/4	502		
D	Return Air Opening Width	14-15/16	380	18-7/16	468		
E	Condensate Drains Height	1-7/16	38	2-3/16	55		
F	Liquid Line Height	11-3/8	290	17-1/2	445		

Outdoor Unit Dimension

Unit:inch(mm)

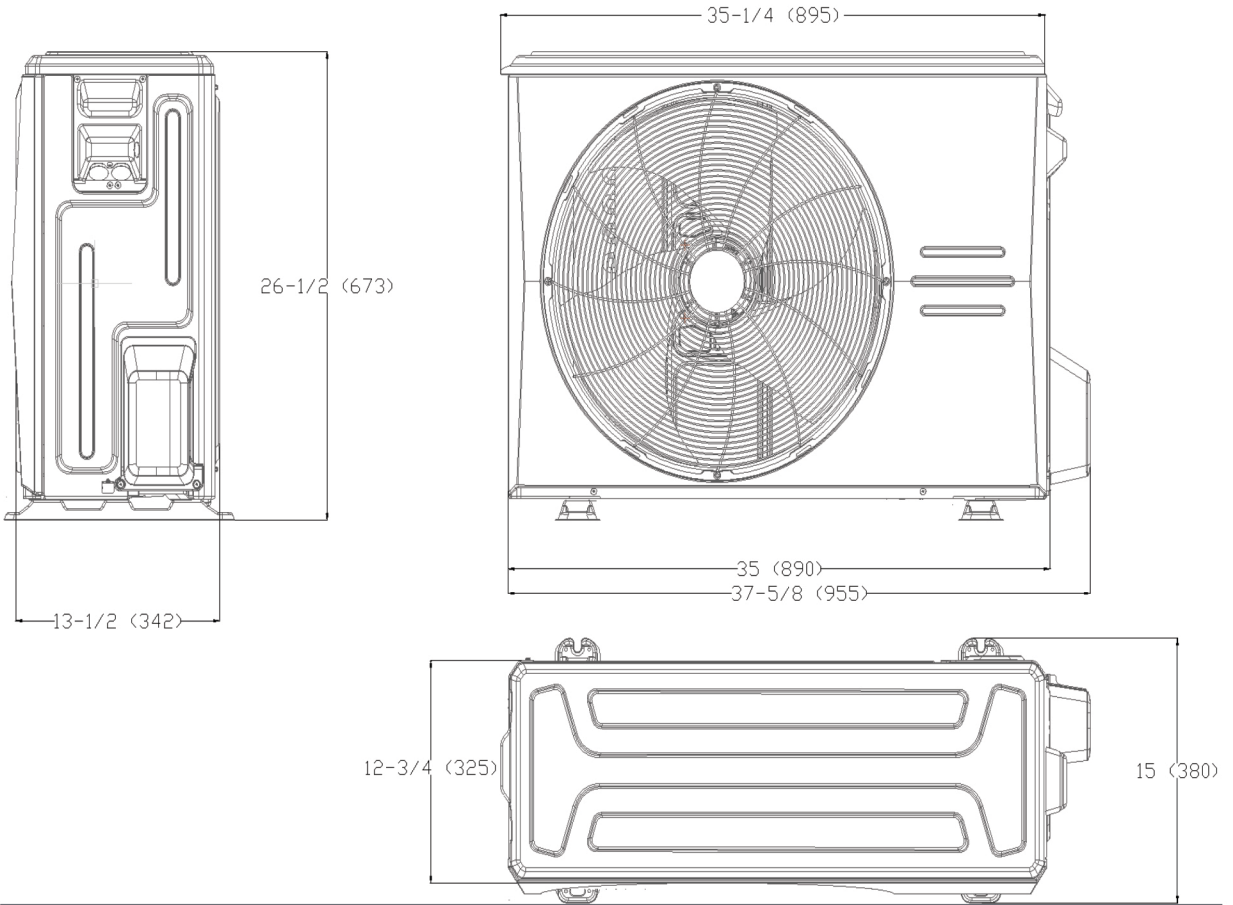

Installation Instruction For Outdoor Unit

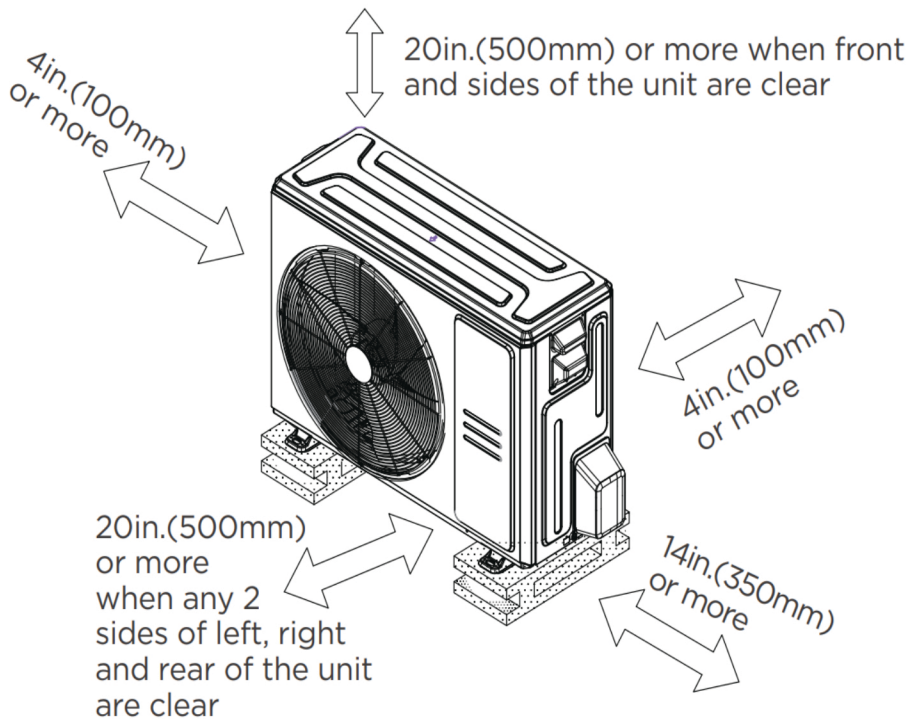

## Features

- Multi-position installation: horizontal(left or right), vertical( up or down)
- Aluminum Coil
- R454B refrigerant sensor
- Easy Maintenance
- Multiple control options available:
  - Two way communication wired controller with built-in WiFi:120N(X6W)
  - Third-Party 24V Thermostat